

WCDMA Physical Layer

NOKIA

Outline

- Physical Layer Functions
- 3GPP WCDMA Parameters
- Modulation
- Channelization
- Scrambling
- Initial Synchronization

Downlink Channel Transmission

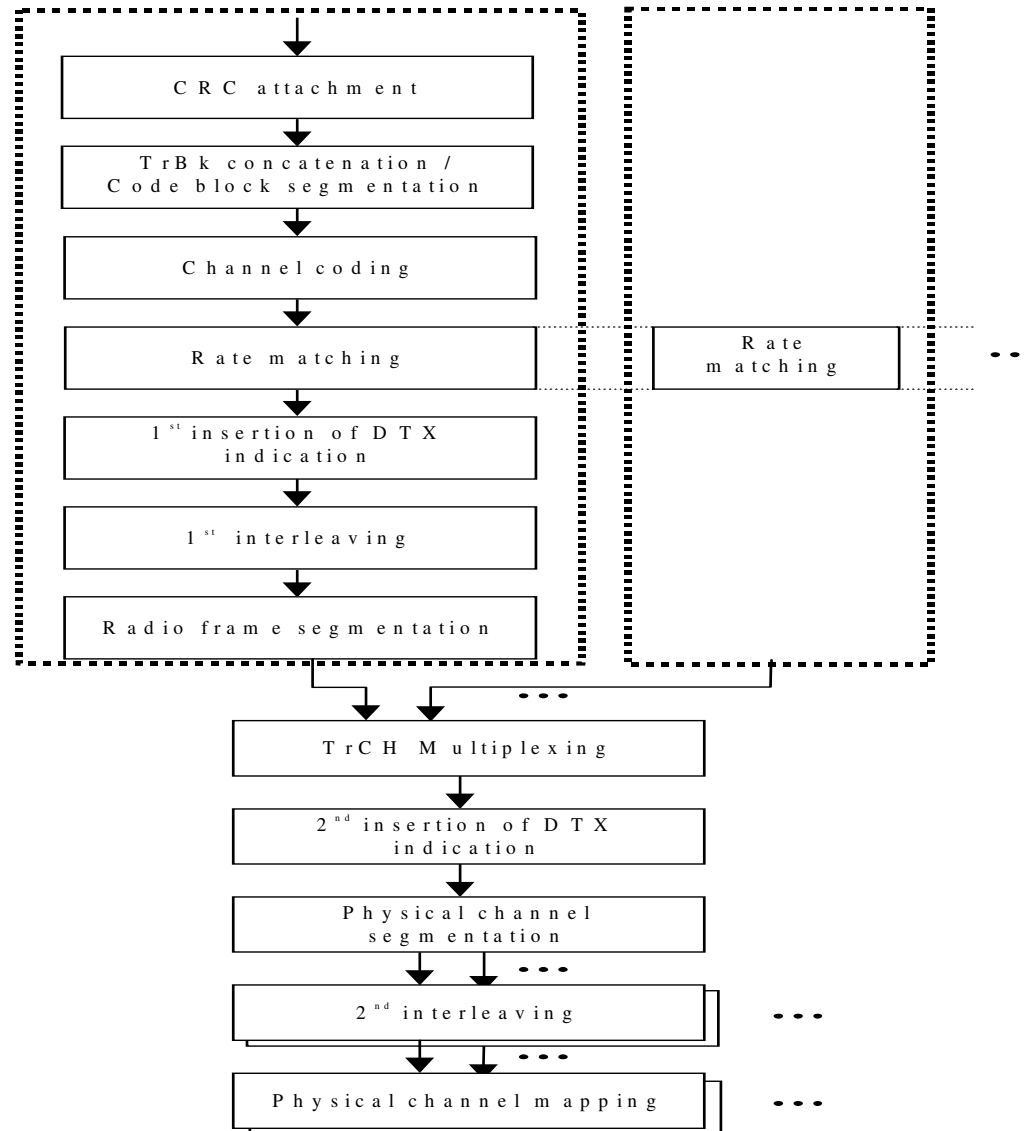

Physical Layer Functions

- Encoding/decoding of transport channels
- Error detection on transport channels and indication to higher layers
- Rate matching/Rate de-matching
- Interleaving
- Multiplexing/De-multiplexing of coded composite transport channels
- Mapping of coded composite transport channels onto physical channels

Physical Layer Functions

- Modulation and spreading / De-spreading and Demodulation of physical channels
- Synchronization
- Soft handover execution
- Power control
- RF Processing, Radio characteristics measurements

3GPP WCDMA Parameters

- Carrier spacing = 5MHz
- Chip rate = 3.84Mcps
- Frame Length = 10ms, 15 slots/frame, 2560 chips/slot
- Uplink SF = 4 to 256
- Downlink SF = 4 to 512
- Uplink Modulation – QPSK, 16QAM
- Downlink Modulation – QPSK, 16QAM, 64QAM
- Channelization codes are OVSF codes, Scrambling codes are complex PRN
- Soft handover with up to 6 base-stations is permitted.
- Fast power control commands: 1500Hz.

FDD Operating Bands

• Band	Uplink	Downlink
• I	1920 – 1980 MHz	2110 –2170 MHz
• II	1850 –1910 MHz	1930 –1990 MHz
• III	1710-1785 MHz	1805-1880 MHz
• IV	1710-1755 MHz	2110-2155 MHz
• V	824 – 849 MHz	869-894 MHz
• VI	830-840 MHz	875-885 MHz
• VII	2500-2570 MHz	2620-2690 MHz
• VIII	880 – 915 MHz	925 – 960 MHz
• IX	1749.9-1784.9 MHz	1844.9-1879.9 MHz
• X	1710-1770MHz	2110-2170 MHz

Modulation

- QPSK, 16QAM, 64QAM modulations are supported.
- Based on modulation type used bits are grouped into 2(QPSK), 4(16QAM), 6 (64QAM) to form a symbol
- For each symbol I,Q values to be transmitted are mapped as per 3GPP specs

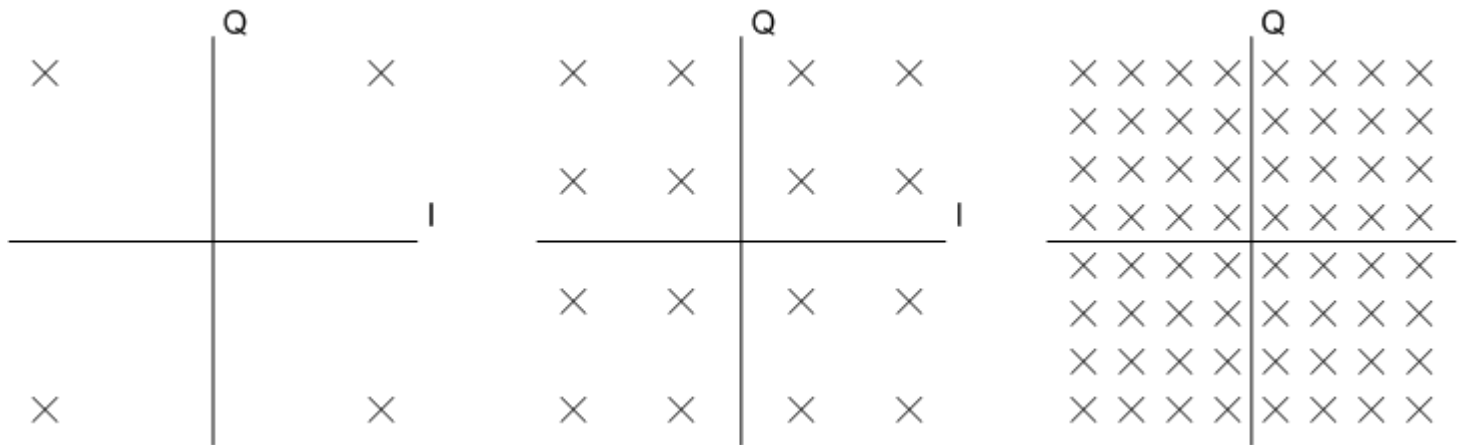

Channelization

- Channelization codes are used to separate different transmissions or channels from the same device
- Each physical channel from a UE or cell uses different channelization code
- Channelization codes do spreading, i.e. increase the signal BW from bit rate to chip rate
- Different UE can use same channelization codes for UL transmission

Channelization

- Orthogonal codes, based on OVVSF (orthogonal variable spreading factor) technique are used
- Channelization codes are picked from a code tree
- Once a code is picked, no other codes from its sub-tree can be picked

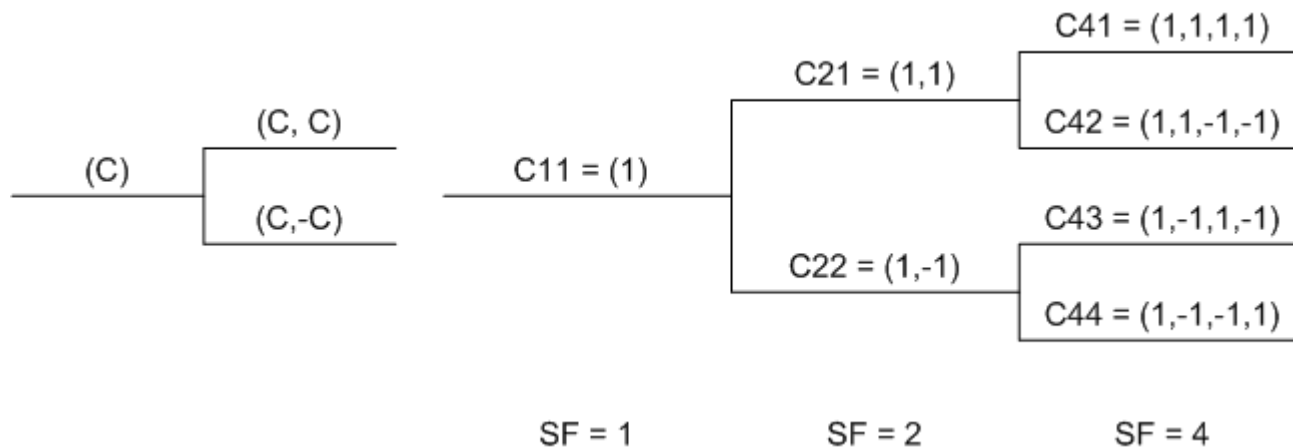

Scrambling

- Scrambling codes are used to separate different transmitting devices
- Each UE, Cell uses a unique scrambling code
- Scrambling codes do not spread the signal, BW remains unchanged @ chip rate
- Scrambling codes are complex pseudo random number sequence

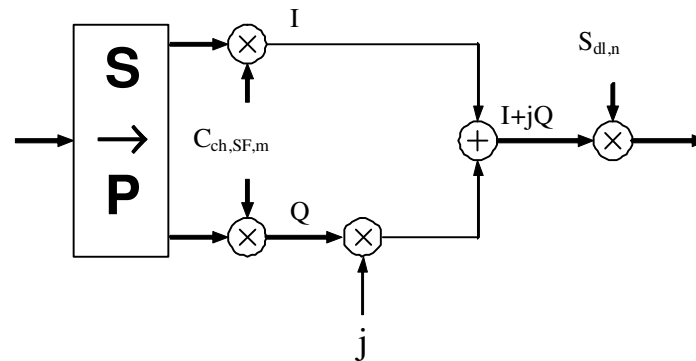

Downlink Channelization, Scrambling and Modulation

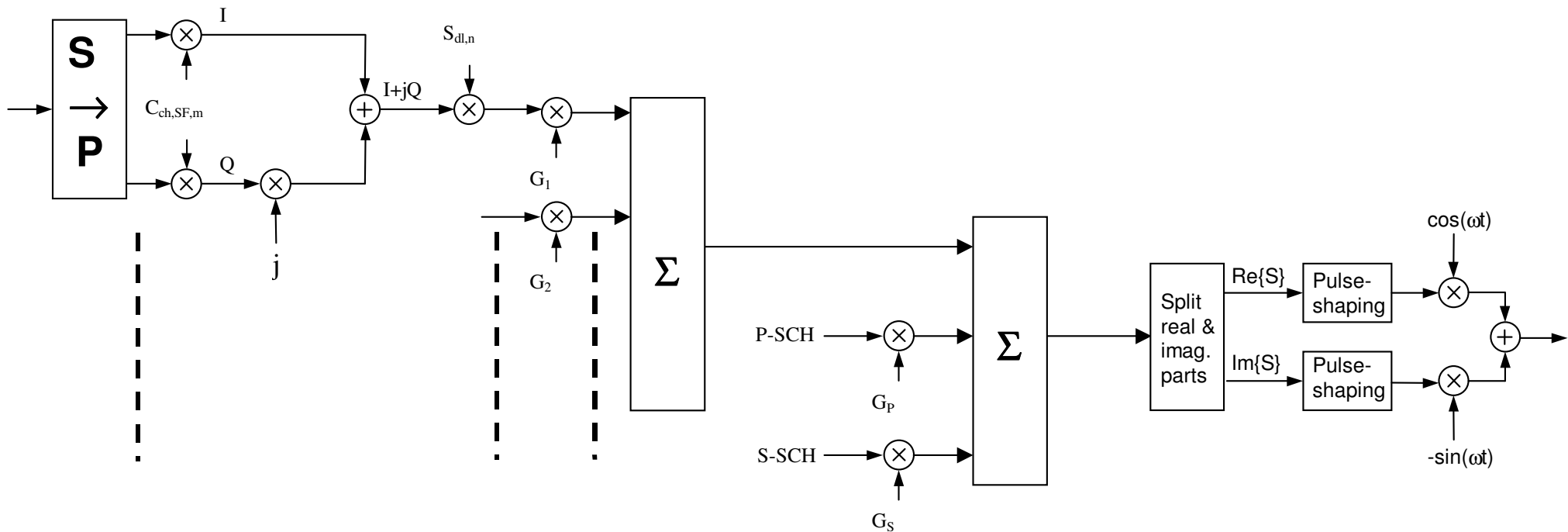

Uplink Channelization, Scrambling and Modulation

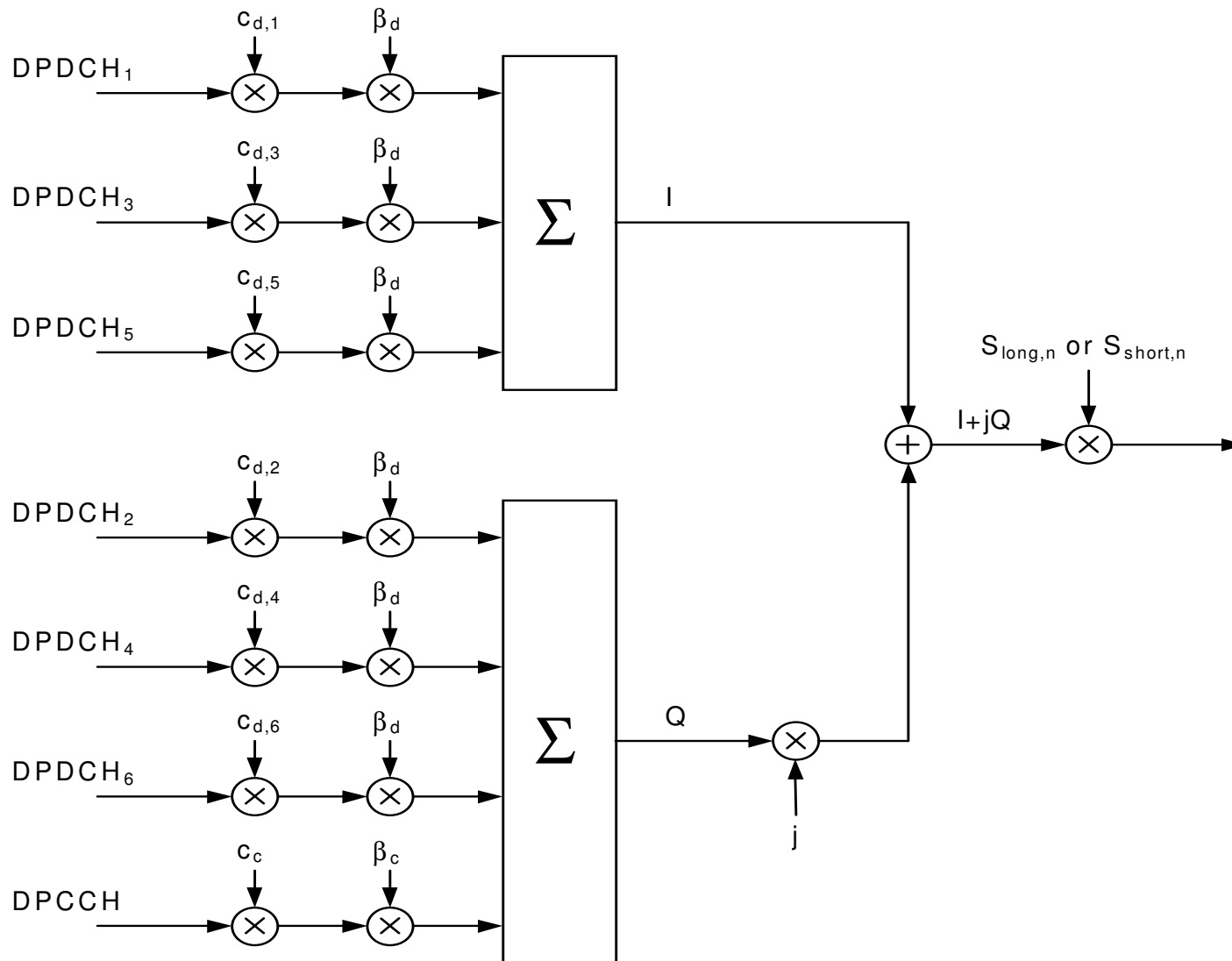

Initial Synchronization

- Three step process to identify
 - Slot timing of the cell
 - Frame timing of the cell
 - Scrambling code of the cell
- UE is capable of receiving DL transmission once the above 3 are available
- SCH (primary and secondary) and CPICH channels are used for this purpose

Physical Channel - SCH

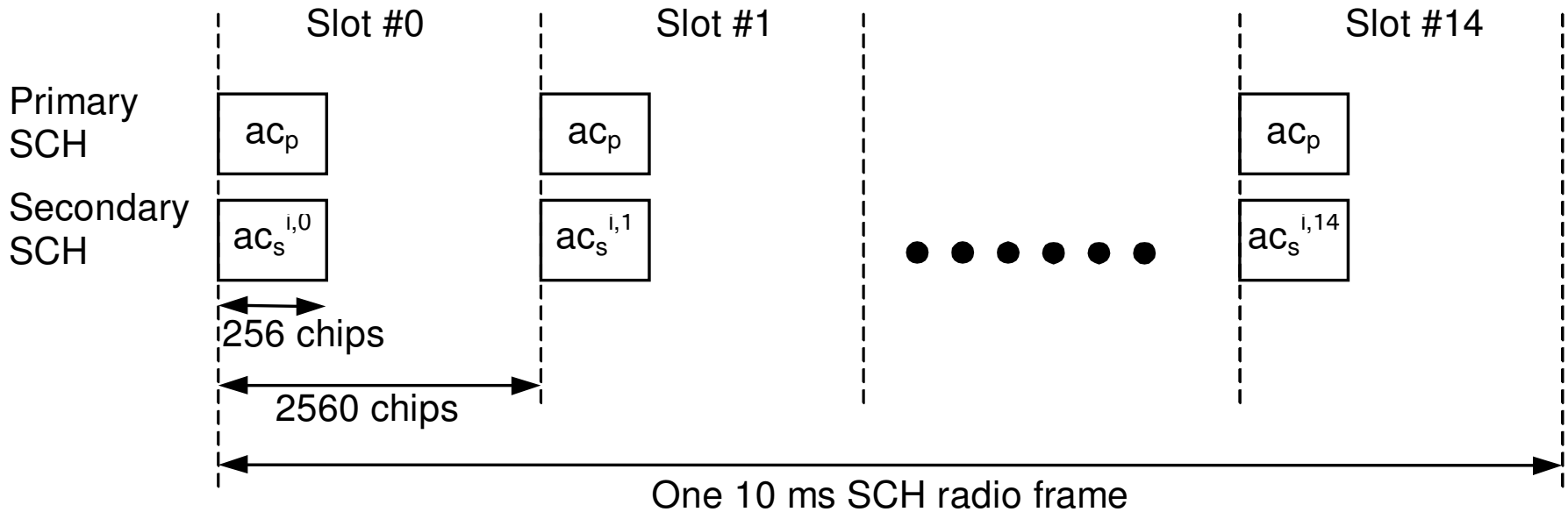

- primary - SCH, same for every cell, no channelization/scrambling used
- Number of scrambling codes for DL = 512, divided into 64 code groups
- Secondary - SCH, indicates which of the 64 code groups scrambling code of that cell belongs to, no channelization/scrambling used

15 Broadcast over entire cell

Physical Channel - CPICH

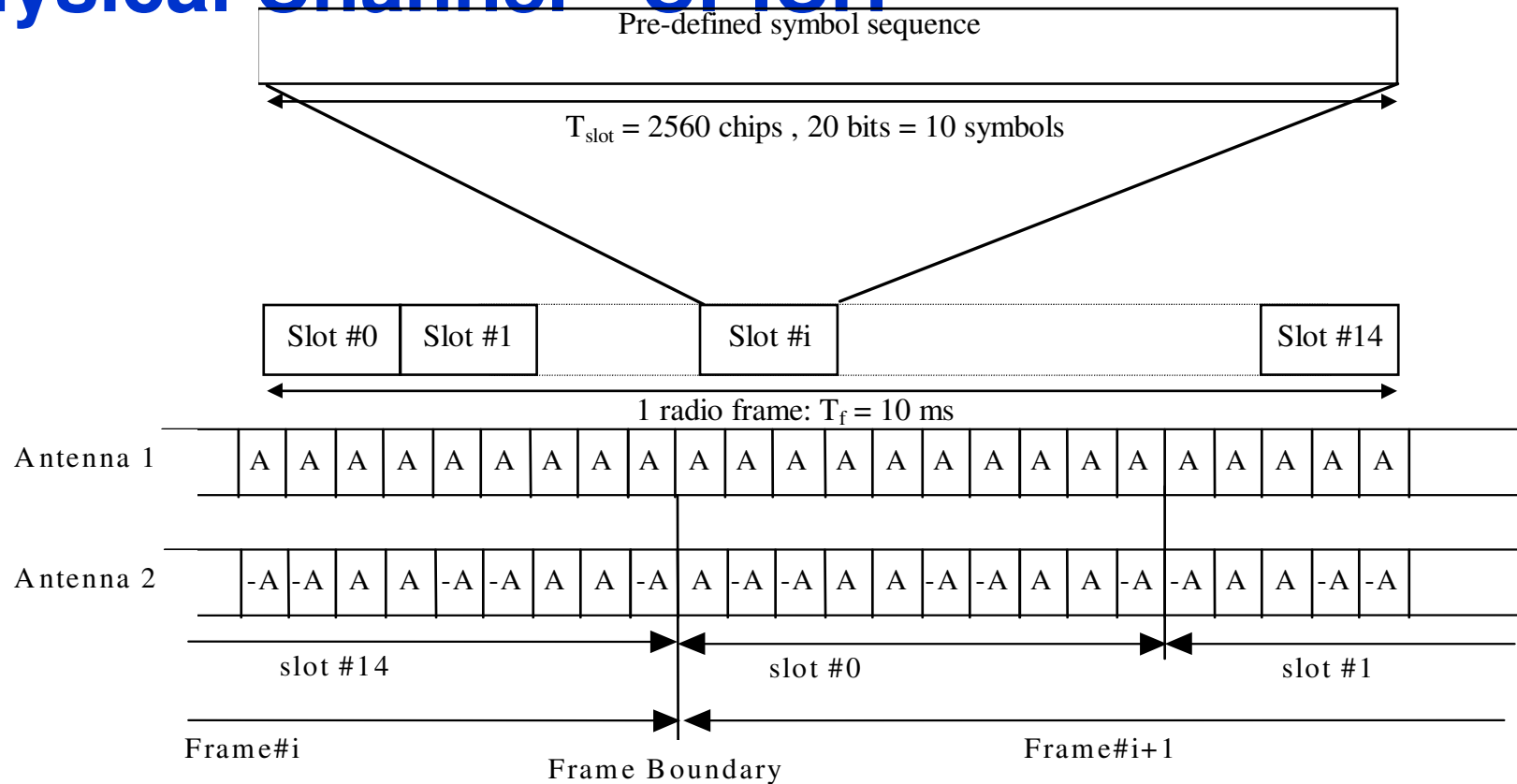

- Uses Fixed channelization code and the scrambling code of the cell
- Broadcast over entire cell
- Used for channel estimation and initial synchronization

Initial Synchronization

- Slot Timing
 - Correlate the incoming chips with PSC word over a slot
 - Correlation peak indicates the location of PSC word and hence the start of the slot
- Scrambling code group
 - 16 SSC words are defined by 3GPP
 - 64 code words (each containing 15 SSC words from above) are defined by 3GPP
 - Receive the SSC words being transmitted at start of slot for 15 consecutive slots (1 frame)
 - Identify which of the 64 code words is being transmitted to find scrambling code group

Initial Synchronization

- Frame timing
 - Identify the phase of the code word to find frame start timing of the cell
- Scrambling code
 - Receive known sequence of pilots using all 8 scrambling codes from the scrambling code group
 - The scrambling code that gives best results is the scrambling code of the cell

Physical Channel - PCCPCH

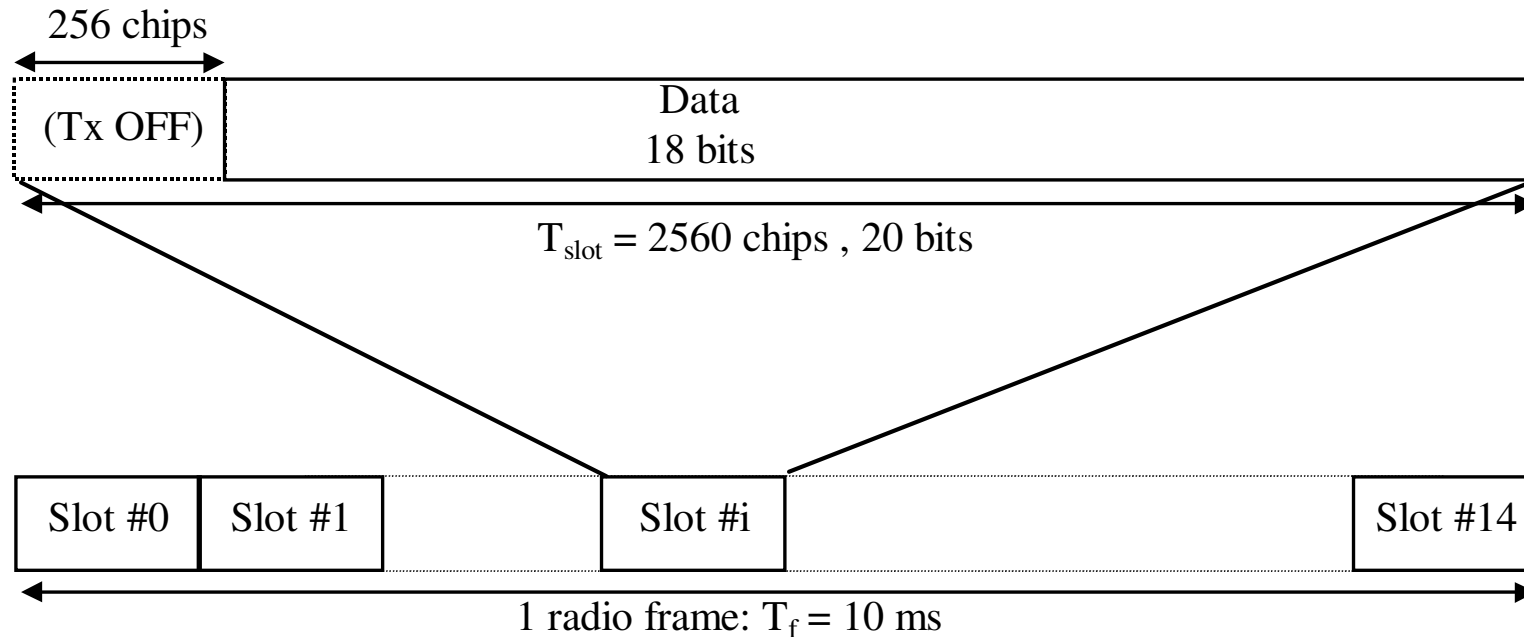

- Broadcast over entire cell, with OVSF code #1
- The 'Tx-off' space is taken up by the SCH channel
- Contains the BCH transport data - System information
- Fixed spreading factor (=256)
- This is the only channel with fixed channel coding scheme.

FDD Physical Channels

- Common Pilot Channel (P-CPICH)
- Synchronization Channel (SCH)
- P-CCPCH
- S-CCPCH
- Paging Indication Channel (PICH)
- Physical Random Access Channel (PRACH)
- Acknowledge Indication Channel (AICH)
- Dedicated Channel (DPCH): contains DPCCH (L1 ctrl) and DPDCH(data) fields.
- HSDPA channels – HS-SCCH, HS-DSCH and HS-DPCCH (rel5)
- E-DCH channels – E-DPCCH, E-DPDCH, E-AGCH, E-RGCH and E-HICH (rel6)
- F-DCH (rel6)

Transport Channels

- BCH - carries system wide information
- FACH - downlink common signaling channel
- RACH - uplink common signaling channel
- PCH - paging channel
- DCH - dedicated channel
- E-DCH – HSUPA dedicated channel
- HS-DSCH – HSDPA dedicated channel
- MTCH, MCCH – MBMS transport channels

Transport to Physical Channel Mapping

Transport Channels	Physical Channels
DCH	<ul style="list-style-type: none"> ————— Dedicated Physical Data Channel (DPDCH) ————— Dedicated Physical Control Channel (DPCCH) ————— Fractional Dedicated Physical Channel (F-DPCH)
E-DCH	<ul style="list-style-type: none"> ————— E-DCH Dedicated Physical Data Channel (E-DPDCH) ————— E-DCH Dedicated Physical Control Channel (E-DPCCH) ————— E-DCH Absolute Grant Channel (E-AGCH) ————— E-DCH Relative Grant Channel (E-RGCH) ————— E-DCH Hybrid ARQ Indicator Channel (E-HICH)
RACH	<ul style="list-style-type: none"> ————— Physical Random Access Channel (PRACH)
BCH	<ul style="list-style-type: none"> ————— Common Pilot Channel (CPICH) ————— Primary Common Control Physical Channel (P-CCPCH)
FACH	<ul style="list-style-type: none"> ————— Secondary Common Control Physical Channel (S-CCPCH)
PCH	<ul style="list-style-type: none"> ————— Synchronisation Channel (SCH) ————— Acquisition Indicator Channel (AICH) ————— Paging Indicator Channel (PICH) ————— MBMS Notification Indicator Channel (MICH)
HS-DSCH	<ul style="list-style-type: none"> ————— High Speed Physical Downlink Shared Channel (HS-PDSCH) ————— HS-DSCH-related Shared Control Channel (HS-SCCH) ————— Dedicated Physical Control Channel (uplink) for HS-DSCH (HS-DPCCH)

THANKS 😊

Q & A ?

DISCUSSION.FORUM.NOKIA.CO

M/VTUEDUSAT

Go To discussion.forum.nokia.com

Register / Login

Search Forums

- Today's Posts
- FAQ
- Mark Forums Read

Go To Market

- Getting Started with Mobile Development
- Device Specifications
- Tools and SDKs
- Documentation
- Knowledge Base
- Training
- Developer Programs



Welcome

If this is your first visit, be sure to check out the [FAQ](#) by clicking the link above to proceed. To start viewing messages, select the forum that you want to visit from the selection below. You must register before you can post: click the register link above to proceed.

Developer Discussions

Feedback to Forum Nokia, Open Discussion, Jobs and News

Forum	Last Post	Threads	Posts
Forum Nokia Services Feedback Feedback on Forum Nokia Services; Series 40 and S60 Platforms; Tools and SDKs; Developer Resources	Typos in S60 5e Examples... by hqohel Yesterday 21:30 »	1,322	5,111
Open Discussions General Discussions; News, Announcements and Job Listings	Congratulations to Gaba88... by TurboC Today 03:50 »	8,831	23,921

Development Platforms

Forum	Last Post	Threads	Posts
Mobile Java General; Tools and SDKs; Media; Networking & Messaging & Security; Games;	encoding associations in j2me... by manjul_saini Today 06:23 »	34,436	119,888
Symbian C++ General; Tools and SDKs; Media (Graphics and Sounds); Networking & Messaging; User Interface; Carbide.c++ IDE and plug-ins; Installation, Certification and Security	DRM ptected music file by er.nisha Today 06:22 »	63,263	255,916
Flash Lite on Nokia Devices	Motion Path by darklord18 Yesterday 22:47 »	602	2,653
Open C/C++	How to put video on... by greenhua Today 03:07 »	570	2,418
Python	how to make buffons on touch...	5,271	29,161

Community: **Developer Discussion Boards**

Once logged in,
Scroll down





- Search Forums
- FAQ
- Mark Forums Read
- My Account
- Today's Posts
- New Posts
- My Profile
- Subscribed Threads
- Private Messages
- Who's Online
- Open Buddy List
- Go To Market
- Getting Started with Mobile Development
- Device Specifications
- Tools and SDKs
- Documentation
- Knowledge Base
- Training
- Developer Programs

Developer Discussions

Feedback to Forum Nokia, Open Discussion, Jobs and News

Forum	Last Post	Threads	Posts
 Forum Nokia Services Feedback Feedback on Forum Nokia Services; Series 40 and S60 Platforms; Tools and SDKs; Developer Resources	Typos in S60 5e Examples... by hgohel Today 02:00 »	1,322	5,111
 Open Discussions General Discussions; News, Announcements and Job Listings	Congratulations to Gaba88... by TurboC Today 08:20 »	8,831	23,921

Development Platforms

Forum	Last Post	Threads	Posts
 Mobile Java General; Tools and SDKs; Media; Networking & Messaging & Security; Games;	Unable to Install Midlet... by hartti Today 11:14 »	34,436	119,889
 Symbian C++ General; Tools and SDKs; Media (Graphics and Sounds); Networking & Messaging; User Interface; Carbide.c++ IDE and plug-ins; Installation, Certification and Security	HTTP Transactions running in... by chandran.biju007 Today 11:26 »	63,265	255,928
 Flash Lite on Nokia Devices	Motion Path by darklord18 Today 03:17 »	602	2,653
 Open C/C++	STLport Query by wizard_hu_ 2009-08-13 14:18 »	569	2,417
 Python	how to make buttons on touch... by gaba88 Today 09:58 »	5,270	29,160
 Qt for S60	Which file controls the... by rannwihit Today 10:35 »	367	2,128



Themes and Mobile Design

Forum	Last Post	Threads	Posts
 Mobile Design and User Experience	NokiaCV: Nokia's Computer... by torsak1 Yesterday 08:25 >>	72	334
 Themes/Carbide.ui	Bug report: right softkey... by alemar84 Today 00:16 >>	936	3,426

Post all your questions in VTU EDUSAT section

VTU EDUSAT

Discussion Board for VTU EDUSAT Training 2009

Forum	Last Post	Threads	Posts
 General Discussion Discussions concerning VTU EDUSAT	Never	0	0
 Modems & Hardware Engine Discussions concerning Modems & Hardware Engine	Never	0	0

Local Language Forums

Or can directly go to discussion.forum.nokia.com/VTUEDUSAT

These Discussion Groups are for discussion of programming issues in Chinese, Russian and Spanish languages

Forum	Last Post	Threads	Posts
 Chinese Application Development - 中文应用开发讨论区 For discussion of Chinese development issues - 关于中文应用开发的讨论	 如何只保留导航面板, 隐藏其余面板, 上下文面板 by topocheng Today 06:20 >>	18,435	81,625
 Foro en Español (Spanish Forum)	 Problema con Carbide.ui en... by pato1998 2009-08-08 12:38 >>	191	487
 Russian Developer Forum - Форум Российских разработчиков	KERN-EXEC 3 при создани... by SiNoptik Today 05:02 >>	492	3,214

Archive (Read Only)

Archive of old forums and messages. You cannot post new messages in any archived forums.

Forum	Last Post	Threads	Posts
 Mobile Commerce	business problem solution via...	96	181

BACKUP

HSDPA

- Circuit switched Vs Packet switched calls
- Uses 3 physical channels (2 on the DL, 1 on the UL)
- HS-PDSCH
 - Shared data channel, SF = 16.
 - HS-PDSCH can use multiple codes
 - Higher order modulation 16-QAM, 64QAM
 - To achieve greater peak data rate
 - Shared channel allows dynamic allocation of resources among users (e.g. guided by channel quality indicator from UE)

HSDPA

- HS-SCCH
 - Channelization-code-set information
 - Modulation scheme information
 - Transport-block size information
 - Hybrid-ARQ process information
 - Redundancy and constellation version
 - New data indicator
 - UE identity
- HS-DPCCH - UL
 - ACK/NACK
 - CQI
- No soft handover, UTRAN can command serving cell change
- New concept of hybrid ARQ (HARQ)

HARQ – Hybrid Automatic Repeat Request

- Channel coding (forward error correction) relies on transmitting redundant bits so that the receiver can perform error correction
- Idea with hybrid ARQ is that if the UE does not receive a block correctly (i.e. CRC pass), it still contains useful information
- Some additional information can be transmitted and added to what has been received until the message is decoded successfully
- Chase combining (CC): The **SAME** bits are transmitted again and soft combined with the bits that the UE has already received
- Incremental redundancy: Some **NEW** parity bits are transmitted which can be concatenated with the already received bits to help decode the message
- Constellation remapping : The **SAME** bits are transmitted but mapped onto the IQ constellation in a different way (16 QAM only)
- Redundancy version bits on the HS-SCCH indicate which of these possibilities is being performed

HARQ – Hybrid Automatic Repeat Request

- New data indicator on the HS-SCCH indicates that this is a new transmission, rather than a retransmission -> indicates that all received data is flushed and start decoding from scratch
- Up to 8 multiple HARQ processes run in parallel
- With HARQ retransmission is desirable because it means that just the right amount of resources (power etc) has been used to get the message through to the UE